

Midterm exam PS 30 November 2008

Name:

TA:

Section number:

This is a closed book exam. The only thing you can take into this exam is yourself and writing instruments. No calculators, computers, cell phones, etc. are allowed. Everything you write should be your own work. Cases of academic dishonesty will be referred to the Dean of Students office, which has the power to suspend and expel students. Partial credit will be given: math mistakes will not jeopardize your grade. This exam has four parts. Each part is weighted equally (12 points each). Please show all steps of your work and explain what you are doing at each step. Correct answers alone are worth nothing without a clear and correct explanation of where the answers come from. Clarity and legibility are factors in the grade.

If you have a question, raise your hand and hold up the number of fingers which corresponds to the part you have questions about (if you have a question on Part 2, hold up two fingers). If you need to leave the room during the exam (to use the restroom for example), you need to sign your name on the restroom log before leaving. You can only leave the room once.

When the end of the exam is announced, please stop working immediately. The exams of people who continue working after the end of the exam is announced will have their scores penalized by 30 percent. Please turn in your exam to your TA. When you hand in your exam, please write your name down on the log. Please write all answers on this exam—if you write on the reverse side of pages, please indicate this clearly. Good luck!

1	
2	
3	
4	
total	

Part 1. "Tina, you're doing a heck of a job."

The President is deciding whom to appoint to the position of Undersecretary of the Department of Health and Human Services. The President's chief political advisor recommends Tina Treasurer, the wife of one of the President's chief campaign fundraisers, Terry "Moneybags" Treasurer. The Director of the Centers for Disease Control recommends Dr. Ralph Regression, a university professor who studies how epidemics spread in highly mobile populations. The President chooses among these two recommendations.

After the President announces his choice, Don Director, the director of the American Cancer Society, must decide whether or not to attack the new appointee's qualifications with a media campaign. Regardless of whether or not the media campaign is executed, it will not result in the appointee being removed from the position.

The President receives a utility of 5 units for hiring Tina and utility of 0 units for hiring Ralph. Don Director receives a utility of -8 units if the job goes to Tina and a utility of 0 units if the job goes to Ralph.

In addition to these utilities, a media campaign by the American Cancer Society depletes some of the President's political capital, costing him 7 units of utility, regardless of whom the President appoints. Media campaigns are expensive and cost Don Director 4 units of utility, regardless of whom the President appoints.

a. Model this situation as an extensive form game. What is the subgame perfect Nash equilibrium in this game? Who will be appointed? Will Don engage in a media campaign? (4 points)

b. Now Don runs for the open Congressional seat in his district. Don has a passion for health policy and thinks he can be more effective in Congress. Because Don is now a candidate for office, the media exposure that he receives from attacking Tina is a “bonus” which increases his utility by an additional 10 units. Don gets no media coverage from attacking Ralph; CNN and MSNBC will dismiss Don as a joke and not cover the story. Everything else is the same as in part a. above (for example, a media campaign still costs Don 4 units and the President 7 units).

Model this situation as an extensive form game. What is the subgame perfect Nash equilibrium in this game? Who will be appointed? Will Don engage in a media campaign? How do Don’s political ambitions affect his influence on the President? (4 points)

c. CNN and MSNBC have noticed that FOX News covers any kind of conflict and does better in the ratings battle. CNN and MSNBC now feel it is their duty to cover any type of conflict, and now Don gets the additional bonus benefit of media exposure (10 units) when he attacks either Tina or Ralph. Everything else is the same as in part a. above (for example, a media campaign still costs Don 4 units and the President 7 units).

Model this situation as an extensive form game. What is the subgame perfect Nash equilibrium in this game? Who will be appointed? Will Don engage in a media campaign? How does the change in the benefits of media coverage affect Don’s influence on the President’s appointment decision? (4 points)

Part 2. State A and State B are in an alliance. However, as international political circumstances change, their payoffs from the alliance change. When such a change occurs, the member states have to choose between Cooperation (*C*) and the Status Quo (*SQ*). International political circumstances determine e , the importance of further alliance cooperation.

The two states play the following game.

		State B	
		C	SQ
State A	C	$1+e, 1+e$	$e, 0$
	SQ	$0, e$	$1, 1$

a. The pure strategy Nash equilibria of this game depend(s) on the value of e . Fill in the table below. Note for example that $-1 < e < 0$ means that e is between -1 and 0 . If there is no pure strategy Nash equilibrium, write “no pure strategy NE”. (4 points)

When	the pure strategy Nash equilibria is/are:
$e < -1$	
$-1 < e < 0$	
$e = 0$	
$0 < e < 1$	
$1 < e$	

b. The mixed strategy Nash equilibrium of this game also depends on the value of e . Fill in the table below. If there is no mixed strategy Nash equilibrium, write “no mixed strategy NE.” If no mixed strategy Nash equilibrium exists, please explain briefly why in the table. Also, please write down your mixed strategy Nash equilibrium in the form we discussed in class: “State A plays C with probability blank, and plays SQ with probability blank, and State B plays C with probability blank, and plays SQ with probability blank.” (4 points)

When	the mixed strategy Nash equilibrium is:
$e < -1$	
$-1 < e < 0$	
$e = 0$	
$0 < e < 1$	
$1 < e$	

		State B	
		C	SQ
State A	C	$1+e, 1+e$	$e, 0$
	SQ	$0, e$	$1, 1$

c. Now consider state A's expected utility in the mixed strategy Nash equilibrium. Fill in the table below. If there is no mixed strategy Nash equilibrium, write "no mixed strategy NE." If there is a mixed strategy Nash equilibrium, write down state A's expected utility in the mixed strategy Nash equilibrium. (4 points)

When	state A's expected utility in the mixed strategy Nash equilibrium is:
$e < -1$	
$-1 < e < 0$	
$e = 0$	
$0 < e < 1$	
$1 < e$	

		State B	
		C	SQ
State A	C	1+e, 1+e	e, 0
	SQ	0, e	1, 1

Part 3. In France since the 1980s, the extremist right-wing party FN has long been spreading xenophobic messages, forcing the Conservative party UMP and the Socialist party PS to address the “immigrant problem.” As a result, during the 2007 French Presidential Election, security issues within the *banlieues*, the French equivalent of “inner city” where many immigrants from Africa reside, were of crucial importance. The situation is modeled in the following way.

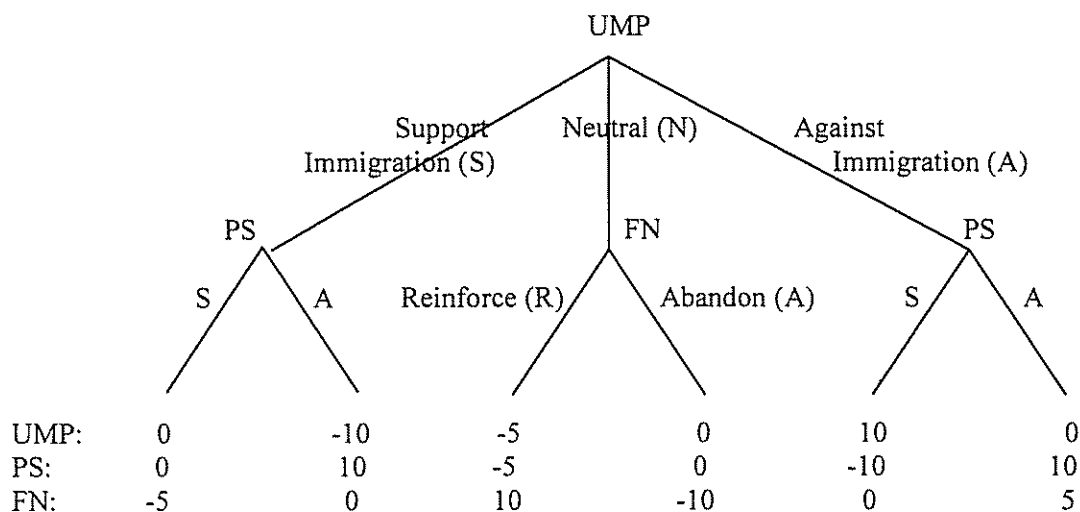

Note that first the UMP can decide to either support immigration (S), remain neutral (N), or take a position against immigration (A). If the UMP supports immigration or goes against immigration, then the PS can take a position supporting (S) or against (A) immigration. If the UMP remains neutral, then the FN can either reinforce xenophobia (R) or abandon xenophobia (A).

a. List each player’s strategies. (4 points)

The UMP’s strategies are:

The PS’s strategies are:

The FN’s strategies are:

b. Find the subgame perfect equilibrium of the game. If there is more than one, write down all of them. (4 points)

c. Find all pure strategy Nash equilibria of the game. For your convenience, the game is shown again below. (4 points)

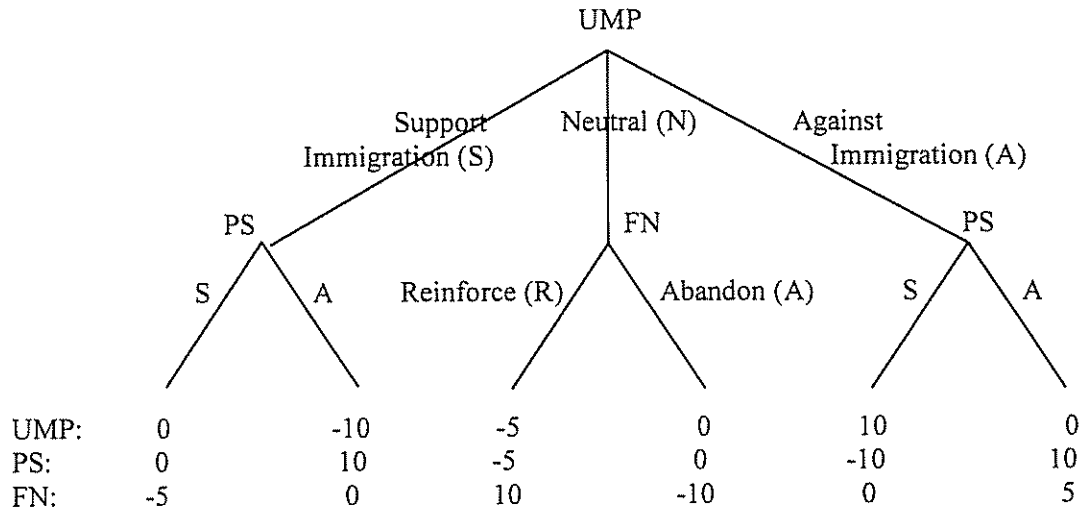

Part 4. Consider the following extensive form game.

Note that payoffs are written as (Player I's payoff, Player II's payoff, Player III's payoff).

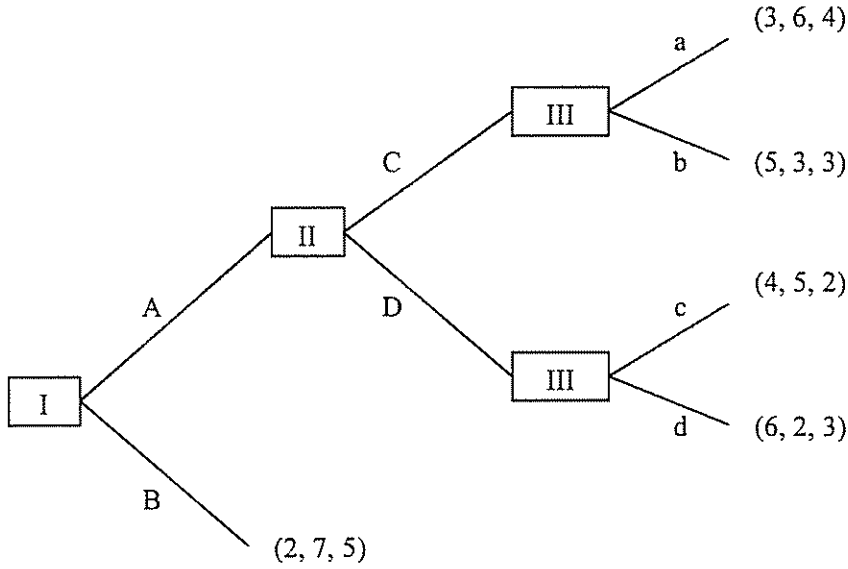

a. Transform the game into a strategic form game. (4 points)

b. Iteratively eliminate strongly dominated strategies. Are the outcomes left after the elimination pure strategy Nash equilibria? (4 points)

c. Write down all pure strategy Nash equilibria of this game. Which pure strategy Nash equilibria involve a non-credible threat? Explain why and indicate which threat(s) are non-credible. (4 points)